

MEGA

16 Ton 4x2 Wheel Drive
New Generation Hydraulic Mobile Crane



PC-16000



ISO : 9001:2015



MEGA *The Unbeatable*

LOAD KING, FUEL SAVER

Technical Specification

⚙️ RATED CAPACITY

16 ton at 1.7 - 2 m radius (Blocked)
Max. hook height 16 m
Max. hook reach 15 m

⚙️ HYDRAULIC SYSTEM

Main pump of 17 gallon. Control Valve-5 Spool double acting with a built in relief valve.

⚙️ VEHICLE PERFORMANCE

Speed max 30 kmph
Gradeability 30% unladen

⚙️ ENGINE

Diesel engine water cooled four cylinder or equivalent engine 48-75 BHP at 2200-2400 RPM

⚙️ STEERING

Fully powered steering unit with twin hydraulic double acting arms
40° articulation on either side & Turning radius upto 7.5 mtr. on outer rear wheels.

⚙️ AXLE LOADING

Front Axle 6500 kg
Rear Axle 9500 kg
Total 16000 kg

⚙️ CLUTCH

11 inch single dry motion heavy duty clutch plate

⚙️ ELECTRICAL SYSTEM

Battery - 12/24 V, Negative earth.

⚙️ STANDARD ACCESSORIES

All weather spacious cabin.
Inbuilt tool box.
Two hydraulically operated stabilizer in front.
Front & rear work light
Reflectors & rear view mirror
Cabin fan
Viper motor
All gauges : water temp., engine oil pressure, RPM cum hour Meter
Front Tyre Protector
4x2 Wheel Drive

⚙️ TRANSMISSION

Heavy duty sliding mesh with 6/8 forward - 2 reverse speed with high & low Range Selector, with original gear box fitted

⚙️ HYDRAULIC BOOM

Hydraulically powered telescopic two to four part Hydraulically operated & synchronized & 4th part power extended with twin extension cylinders
Derricking through two nos. Cylinders.

⚙️ OPTIONAL ACCESSORIES

Fly jib.
Additional Air condition cabin
SLI (Safety load indicator) Hydraulic Cut off
Spark arrester
Fire extinguisher
Front outriggers
Helper/slinger seat
Drag winch

⚙️ BRAKES

Fully air actuated brakes on rear wheel & pneumatically assisted hydraulic brakes on front wheels

HOIST

⚙️ Winch is driven by hydraulic motor employing 04/06 falls of 13 mm. dia rope suitable arrangement (should be given so that move up/down) when boom retract or extended.

TANK CAPACITIES

⚙️ Fuel tank 100 ltrs.
Hydraulic tank 120 ltrs.

PARKING

⚙️ Graduated hand control valve system (at rear wheels only)

DIMENSIONS

⚙️ Overall length 10.50 mtr.
Overall width 2.60 mtr.
Overall height 3.10 mtr.

AXLES

⚙️ Front : rigidly mounted on chassis
Rear : mounted with cradle

WHEEL TACK

⚙️ Front 2060 mm
Rear 1820 mm

TYRES

⚙️ Front - 4 nos. 11.00 x20 - 16 PR
Rear - 2 nos. 14.00 x25 - 20 PR

WHEEL BASE

⚙️ 4900 MM



OMEGA



Stabilizers

A Special Feature for maintaining stability while lifting load at maximum height



Powerful Boom

Hydraulically powered boom with twin extension cylinders



Hydraulic Tank

Cap.120 ltr.



Slinger Seat

Comfortable & Sliding Helper Seat



Front Cabin

Front mounted ergonomically designed for better visibility



Power Steering

With double acting arms 40° articulation on either side

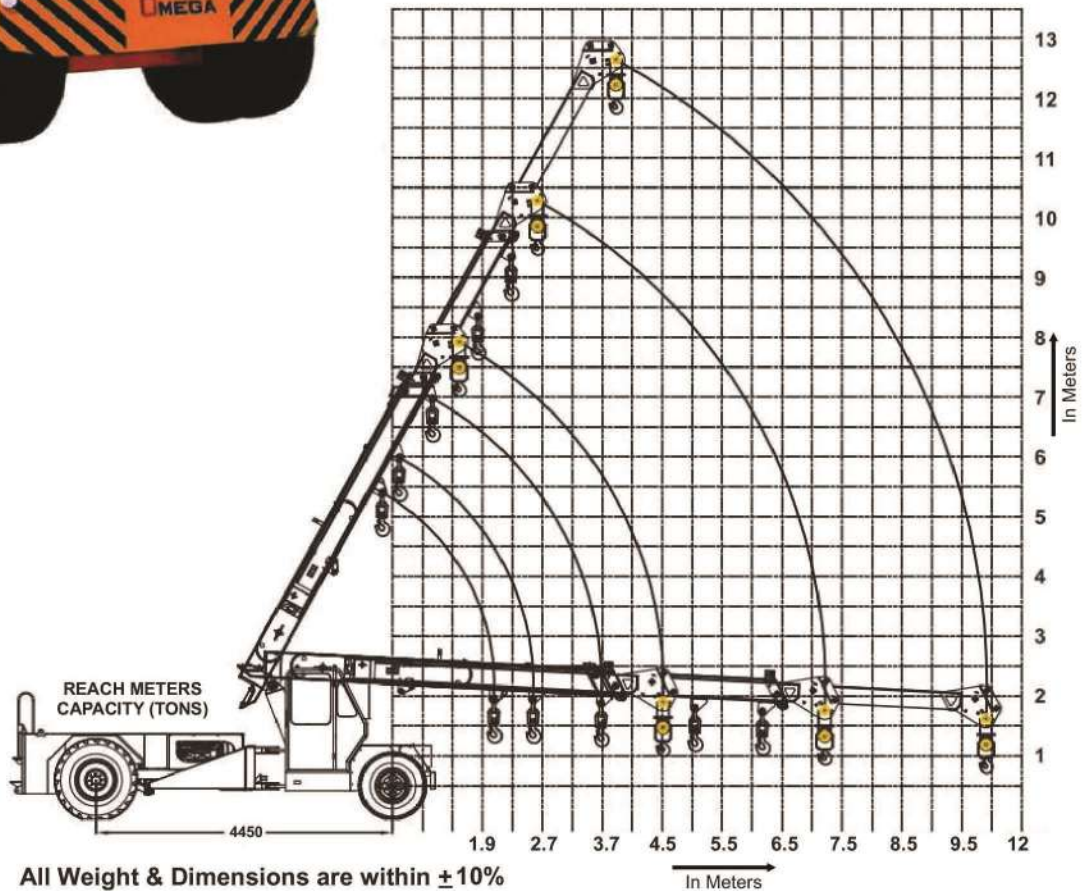

OMEGA

PC-16000

OMEGA *The Unbeatable*



Dealer Network in India & Abroad



INDIA : JAMMU, MANDI, CHANDIGARH, LUDHIANA, JAIPUR, DELHI, FARIDABAD
JODHPUR, LUCKNOW, GUWAHATI, SINGRAULI, AHMEDABAD, BARODA, JABALPUR
SURAT, INDORE, BHILWARA, CUTTAK, BHUBANESHWAR, MUMBAI, VIZAG, PUNE
SECUNDERABAD, CHENNAI, BANGALORE, COCHIN **OVERSEAS :** UAE, SRILANKA

Product Support

Omega Construction Equipment has countrywide infrastructure for service & Spare parts, through highly dedicated and committed engineers, in all the major cities in india.

OMEGA CONSTRUCTION EQUIPMENT PVT. LTD.

Head Office : GF 18, Ozone Center, Sec-12, Faridabad Haryana - 121001

Manufacturing Unit : Plot No. 139, Sec-24, Faridabad Haryana - 121005

Manufacturing Unit-2 : Khasra No. 44, Seekri Pyala Road, Sagarpur, Ballabgarh
Distt. Faridabad Haryana - 121004

Land Line No. : +91-129-4066707 (30 Lines)

E-mail: info@omega.org.in

Web : www.omega.org.in

Dealer :

.....

.....

.....